



Differential Pressure Sensors

QBM65.../C QBM75.../C

for air and non-corrosive gases, with calibration certificate

- Highly accurate measurements with calibration certificate
- Simple and quick to install
- Recalibration service

Use

The calibrated differential pressure sensors are used in circumstances where highly accurate measurements are required, or where there is a (statutory) requirement for regular calibration.

Typical applications include the measurement of positive or negative pressure and pressure differentials in HVAC plants, including the control of duct pressure differentials for fan control, room pressure equalization in VAV systems, and filter and fan-belt monitoring. Other possible uses include the monitoring of specified pressure differentials in production areas and laboratories in the chemical industry, and in hospitals, clean-rooms, warehouses, restaurants, kitchens, etc.

Type summary

Type reference	Measuring range	Max. positive pressure	Output signal	LCD display
QBM75-1U/C	- 50 ... + 50 Pa	5,000 Pa	DC 4 ... 20 mA	No
QBM75.1-1/C	0 ... 100 Pa	5,000 Pa	DC 4 ... 20 mA	Yes
QBM65-1/C	0 ... 100 Pa	5,000 Pa	DC 0 ... 10 V	No
QBM65-3/C	0 ... 300 Pa	5,000 Pa	DC 0 ... 10 V	No
QBM65-10/C	0 ... 1,000 Pa	10,000 Pa	DC 0 ... 10 V	No
QBM65-25/C	0 ... 2,500 Pa	20,000 Pa	DC 0 ... 10 V	No

(Conversion: 100 Pa = 1 hPa = 1 mbar)

Accessories	Name	Type reference /part no.	Remark
	2 m plastic tubing, 5 / 8 mm dia.	No	Included in standard delivery
	3-core connector (round, Lumberg RKC 30/11)	No	
	Mounting bracket (required when mounting the sensor on lagged ducts)	AQB2000	Not included in standard delivery
	Bracket for top hat rail (5 pieces) for top hat rails to DIN, HT 35-7.5	AQB21.2	
	Air duct probe, short (for simple, quick and airtight mounting)	FK-PZ1	Not included in standard delivery (see data sheet N1589)
	Air duct probe, long (with orifice plate for precise measurements)	FK-PZ2	

Ordering and delivery

When ordering, please give name and type reference, e.g.

Differential pressure sensor **QBM65-3/C**

The differential pressure sensors are supplied with a round connector (type: Lumberg RKC 30/11).

If needed, the AQB2000 mounting bracket, the AQB21.2 bracket for top hat rail and FK-PZ1 or FK-PZ2 duct probes must be ordered as separate items.

The type FK-PZ... duct probes are supplied in packs of two and the AQB21.2 bracket for top hat rail in packs of five.

Equipment combinations

The QBM65.../C differential pressure sensor can be used in combination with all devices or systems capable of handling its DC 0...10 V output signal.

Type QBM75.../C can be used with all devices or systems capable of handling its DC 4...20 mA output signal and having a power supply in the range of DC 11...33 V (2-wire connection).

Mode of operation

The differential pressure sensors use a silicone-rubber diaphragm to register changes in pressure. The deflection of the diaphragm is registered by the ceramic lever and converted into an electrical signal.

This signal is conditioned by the built-in electronic circuit to give a linear DC 0...10 V, or DC 4...20 mA signal representing the measured value.

Mechanical design

The differential pressure sensors comprise the following:

- Sensor housing with integral 3-core connector and hinged cover
- Pressure casing with diaphragm and lever
- Printed circuit board
- Digital display for sensor signal in Pa (only with the **QBM75.1-1/C**)

Mounting and installation notes

Mounting instructions are enclosed with the differential pressure sensors.

The differential pressure sensors are suitable for direct mounting on ducts, walls or ceilings and in control panels. Note that the sensors must be mounted vertically.

Where possible, the pressure connection nozzles should be at the bottom, or if necessary, to the side, and they should always be higher than the duct probes. Horizontal mounting (with the hinged cover at the top or bottom) is **NOT RECOMMENDED**. If horizontal mounting cannot be avoided, account must be taken of deviations in the measured value (see "Factory calibration" below).

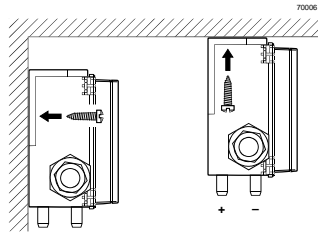

Caution :

If the pressure connection nozzles face upwards, or are at a lower level than the duct probes, condensation can collect inside the unit, causing damage to the sensor.

For direct mounting on lagged ducts, the sensor can be fitted with an **AQB2000** mounting bracket (see "Accessories").

A 2 m length of plastic tubing is supplied with the sensor and can be adapted to the duct probes on site. Connect the tubing from the lower pressure side to pressure connection nozzle 'P2' or '- '.

Factory calibration

The values given under "Technical data" are valid only when the differential pressure sensor is mounted vertically. Should it be necessary to mount the sensor horizontally, i.e. with the hinged cover at the top or bottom (**NOT RECOMMENDED**), account must be taken of the following deviations in the measured value:

<p>Recommended orientation: Hinged cover in vertical position. Signal: As per factory calibration</p>	<p>NOT RECOMMENDED: Hinged cover facing downwards. Signal QBM65.../C and QBM75.1-1/C: approx. 10 Pa above actual pressure. Signal QBM75.../C: approx. 14 Pa above actual pressure.</p>	<p>NOT RECOMMENDED: Hinged cover facing upwards. Signal QBM65.../C and QBM75.1-1/C: approx. 10 Pa below actual pressure. Signal QBM75.../C: approx. 14 Pa below actual pressure.</p>
---	---	---

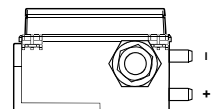
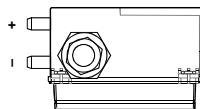
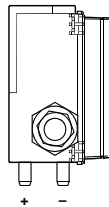

Recalibration service

Siemens Building Technologies provides a recalibration service for these pressure sensors. Under 'normal' conditions, recalibration should be repeated at 12-month intervals (or in accordance with the relevant statutory requirements). A recalibrated sensor should not be stored for more than 12 months (or it should be commissioned within that period).

In the case of sensors which are over 10 years old and/or in poor condition, Landis & Staefa reserves the right to refuse recalibration and readjustment.

Services included

The recalibration service ¹⁾ comprises the following elements:

- Calibration ²⁾ with record of values
 - Sensor test including repairs and replacement of worn parts.
Repair of the measuring element where necessary
 - If necessary, readjustment ³⁾ and recalibration
 - Completion and supply of a new calibration certificate
- Despatch and registration (original sensor returned to the customer)

¹⁾ Handling and invoicing reference S/QBM65.../C or S/QBM75.../C
²⁾ The sensor is compared with a measuring standard. Deviations are recorded but not corrected
³⁾ The sensor is compared with a measuring standard and any deviations noted are corrected

Technical data

Electrical interface	Power supply	Safety extra low voltage (SELV, PELV)	
	QBM65.../C	Supply voltage	AC 24 V, 50/60 Hz or DC 13.5...33 V
		Max. voltage tolerance	±15 % at AC 24 V
		Power consumption	<0.5 VA
		Current draw	<15 mA
		Output signal	DC 0...10 V, $R_{Load} > 10 \text{ k}\Omega$ (not galvanically separated, 3-wire connection, short-circuit-proof, reversed polarity protection)
	QBM75.../C	Supply voltage	DC 11...33 V
		Power consumption	<0.7 VA
		Current draw	4...20 mA
		Output signal	4...20 mA, $R_{Load} > \frac{\text{Operation voltage} - 11 \text{ V}}{0.02 \text{ A}} \Omega$ (2-wire connection, short-circuit-proof, reverse polarity protection)
Product data	Measuring range	See "Type summary"	
	Measuring element	Piezoresistive (silicone-rubber diaphragm and ceramic lever)	
	Measuring accuracy in correct mounting position and at a room temperature of between 20 ... 25 °C (FS = Full Scale):		
	General:		
	Zero point voltage	<50 mV	
	Zero point current	<0.1 mA	
QBM65-3/C	Zero point	<±0.7 % FS	
QBM65-10/C	Total, linearity and hysteresis	<±1 % FS	
QBM65-25/C	TC zero point	<±0.04 % FS/°C	
	TC sensitivity	<±0.02 % FS/°C	
QBM65-1/C	Zero point	<±1 % FS	
QBM75.1-1/C	Total, linearity and hysteresis	<±2 % FS	
	TC zero point	<±0.10 % FS/°C	
	TC sensitivity	<±0.05 % FS/°C	
QBM75-1U/C	Total, zero point, linearity and hysteresis	<±3 % FS (<±3 Pa)	
	TC zero point	<±0.10 % FS/°C typical	
	TC sensitivity	<±0.05 % FS/°C typical	
	Response time 90 %	<10 ms	
	Nominal pressure	See "Type summary", page 1	
	Max. positive pressure	See "Type summary", page 1	
	Bursting pressure	500 hPa (500 mbar)	
	Suitable media	Air or non-aggressive gases	
	Admissible temperature of medium	0...70 °C	
	Maintenance	No maintenance required, recalibration recommended every 12 months	
Protective data	Degree of protection when mounted in the recommended position	IP 54 to IEC 529	
	Safety class	III to EN 60 730	
	Combustion class	To UL94	
	Hinged cover	HB	
	Pressure casing and housing	V-2	
	Plastic tubing	V-2	

Conditions	Electrical connection	3-core round connector with 1.5 mm ² screw terminals (type Lumberg RKC 30/11)
	Pressure connections	Plastic nozzles, 6.2 mm dia. Lower pressure side identified as 'P2' or ' - '
Mounting	Mounting	Screwed directly to duct or mounted on walls, ceilings or in control panels
	Orientation	Vertical, with pressure connection nozzles downwards (factory calibration)
Environmental conditions	Perm. ambient temperature	
	Operation	0...70 °C
	Storage/transport	-10...+70 °C
	Perm. ambient humidity	<90 % r. h., non-condensing
Standards	Electromagnetic compatibility	
	Immunity to	EN 61000-6-1
	Emissions to	EN 61000-6-3
	CE conformity to EMC directive	89/336/EWG
	C conformity to	
	Australian EMC Framework	Radio Communication Act 1992
	Radio Interference Emission Standard	AS/NZS 3548
Materials	Housing	PC (polycarbonate)
	Hinged cover	ABS
	Pressure casing	PC with 10 % fibre-glass
	Diaphragm	2-component silicone LSR and PC with 10 % fibre-glass
	Plastic tubing	PVC (polyvinylchloride, soft)
Weight / dimensions	Weight (including packaging)	0.2 kg (with round connector)

Connection terminals

QBM65.../C

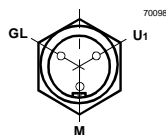

Front view of connector on sensor housing (internally wired at factory)

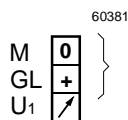

Terminal markings

Supply voltage AC 24 V (SELV) or DC 13,5...33 V

DC 0...10 V output signal (with reference to M)

QBM75.../C

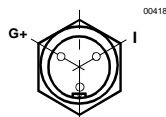

Front view of connector on sensor housing (internally wired at factory)

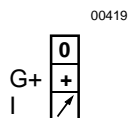

Terminal markings

Supply voltage DC 11...33 V

DC 4...20 mA output signal

Dimensions (All dimensions in mm)

QBM65.../C
QBM75.../C

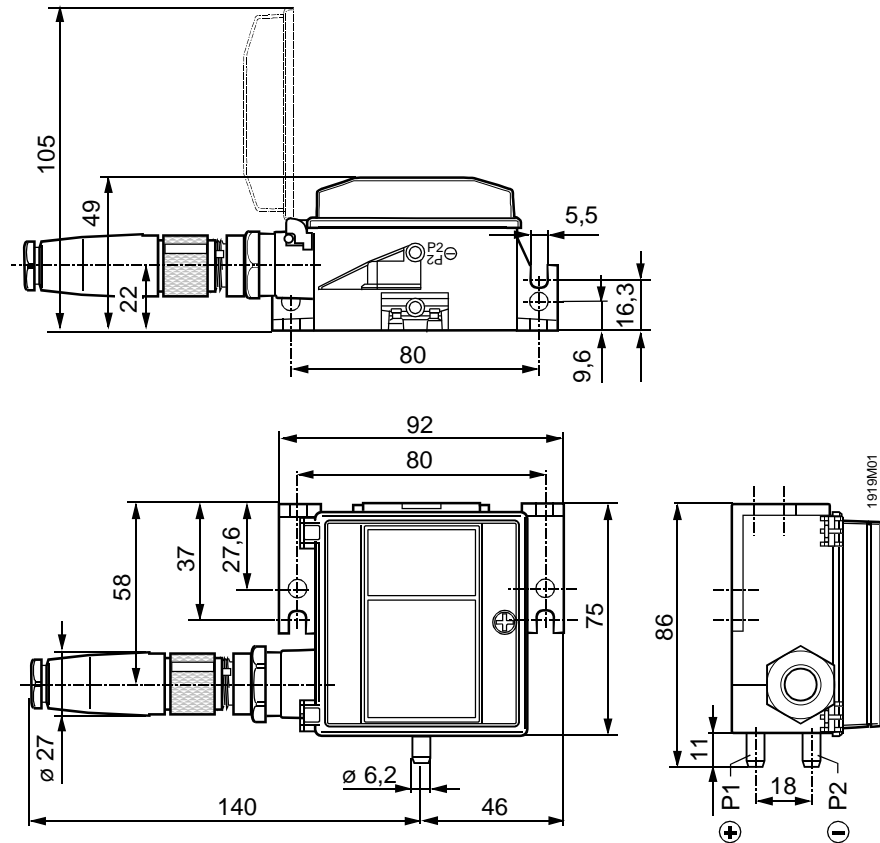

AQB21.2

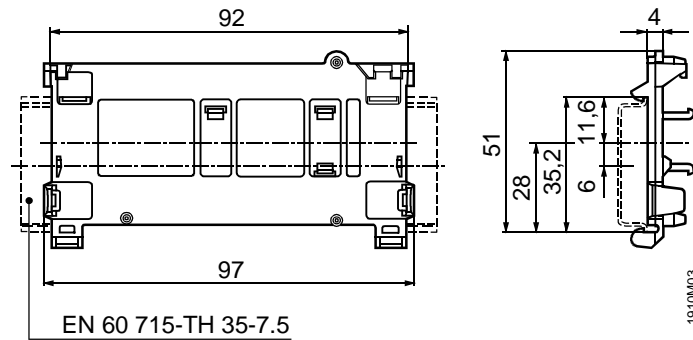

AQB2000

