



Butterfly valves PN6, PN10, PN16, VKF41..

- Grey cast iron housing EN-GJL-250
- DN 40...200
- k_{vs} 50...4000 m³/h
- For fitting between PN 6, PN 10, PN 16 counter-flanges to ISO 7005
- Metallic tight-closing
- Angle of rotation 90°
- No maintenance required
- Can be fitted with type SQK33.00, SQL33.., SQL83.00, SQL35.00 or SQL85.00 electromotoric actuators

Use

For use as a control or shut-off valve in heating, ventilation and air conditioning systems, e.g.:

- In closed circuits
- For 2-position controls (open/closed)
- For boiler and chiller sequencing circuits
- To open or close the flow to a heat exchanger or to complete plant sections
- In applications where minimal leakage through the fully closed valve is allowable

Type summary



Product number	DN	k _{vs} [m ³ /h]	Leakage rate in % of k _{vs} -value	Velocity of flow ¹⁾	
				Water [m/s]	Gas [m/s]
VKF41.40	40	50	0.22	4	40
VKF41.50	50	80	0.14		
VKF41.65	65	200	0.09		
VKF41.80	80	400	0.06		
VKF41.100	100	760	0.04		
VKF41.125	125	1000	0.04		
VKF41.150	150	2100	0.02		
VKF41.200	200	4000	0.01	5.5 ²⁾	55 ²⁾

¹⁾ Recommended maximum velocity of flow and the butterfly valve fully open

²⁾ Only valid with type SQL35.00 and SQL85.00 actuators

k_{vs} Nominal flow rate of cold water (5...30 °C) through the fully open butterfly valve by a differential pressure of 100 kPa (1 bar)

Accessories

Product number	Description
Centering sleeves 	4 centering sleeves are supplied with each butterfly valve, for fitting the valve between PN 10 and PN 16 flanges
ASK33 mounting set 	For mounting SQK33.00, SQL33.. and SQL83.00 actuators on VKF41.. DN 40...200
ASK35 mounting set 	For mounting SQL35.00 and SQL85.00 actuators on VKF41.. DN 150...200

Ordering

Example:

Product number	Stock number	Designation	Quantity
VVF41.50	VVF41.50	Butterfly valve VKF41.40 including centering sleeves	1
SQL33.03	SQL33.03	Actuator SQL33.03	1
ASK33	ASK33	Mounting set ASK33	1

Delivery

Butterfly valve, actuator and mounting set are packed separately.

Spare parts, Rev. no.

See overview, page 6.

Equipment combinations

Butterfly valve	Mounting set	Electromotoric actuator				
		SQK33.00	SQL33..	SQL83.00	SQL35.00	SQL85.00
		Δp _s [kPa]				
VKF41.40	ASK33	200	500			
VKF41.50		300				
VKF41.65						
VKF41.80						
VKF41.100			250	500		
VKF41.125						
VKF41.150		ASK35 ¹⁾	250	500		
VKF41.200	150		300			

¹⁾ Mount SQL35.00 and SQL85.00 with ASK35 on VKF41.. butterfly valves

Δp_s Maximum permissible differential pressure at which the motorized butterfly valve will close securely against the pressure (close off pressure)

Actuator overview

Product number	Actuator type	Operating voltage	Positioning signal	Spring return	Positioning time	Positioning force	Data sheet
SQK33.00	Electro-motoric	AC 230 V	3-position	No	125 s	5 Nm	N4506
SQL33.00						12.5 Nm	
SQL33.03					10 Nm		
SQL83.00		AC 24 V			12.5 Nm		
SQL35.00		AC 230 V			20 Nm	N4505	
SQL85.00		AC 24 V					

Mechanical design

Butterfly valve

Stainless steel disk and shaft. The valve disk closes against an end-stop. The position of the valve disc is indicated by a notch on the front of the shaft.

Mounting set ASK...

In all cases, a mounting set is required to assemble the actuators on a VKF41.. valve.

Flow diagram

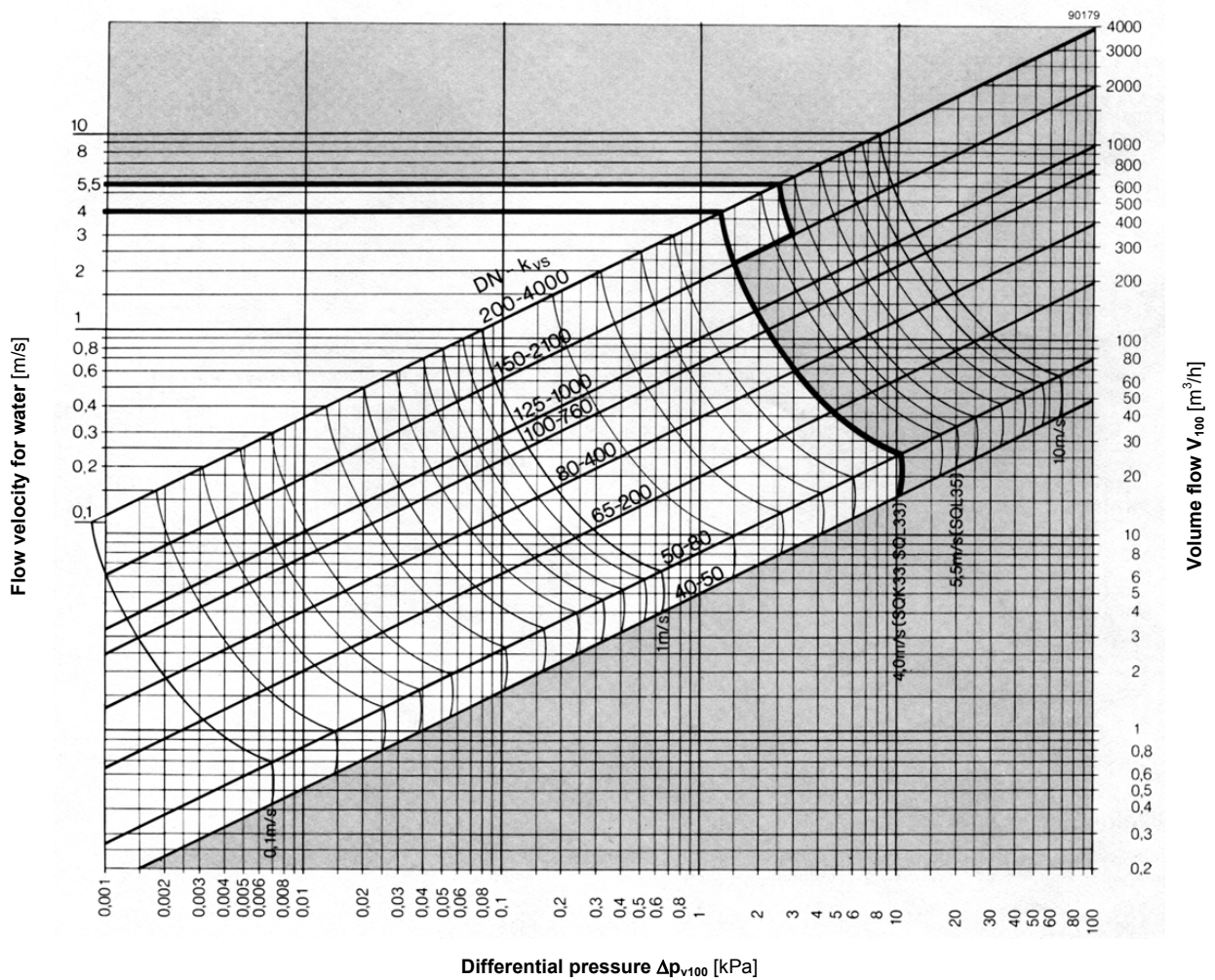

- Δp_{V100} = Differential pressure across the fully open butterfly valve by a volume flow V_{100}
- V_{100} = Volume flow through the fully open butterfly valve
- 100 kPa = 1 bar \approx 10 mWC
- 1 m^3/h = 0.278 l/s water at 20 °C

Engineering notes

The VKF41.. butterfly valves can accommodate flow in either direction.

In heating systems, the valve should preferably be installed in the return, where the seal will be exposed to lower temperatures, so extending its service life.

Warning

To avoid pressure shocks on the butterfly valve, the VKF41.. must be driven to its fully open position (either manually or via positioning signal Y1) prior to activating the pump(s).

Mounting notes

The Mounting Instructions 4 319 8927 0 are enclosed in the product packaging.



VKF41.. butterfly valves can be mounted in PN 6, PN 10, PN 16 applications.

Orientation

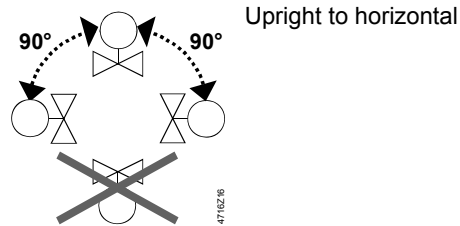

The valve, actuator and mounting set are easily assembled directly on site. There is no need for special tools or calibration.

Commissioning notes

The butterfly valve must be commissioned only with the mounting set and actuator correctly assembled.

- Disk rotated clockwise: Increasing flow
- Disk rotated anti-clockwise: Decreasing flow

Maintenance

The VKF41.. butterfly valves require no maintenance.

Caution

Before performing any service work on the valve, actuator or mounting set:

- Switch off the pump and power supply
 - Close the main shut-off valves in the pipework
 - Release pressure in the pipes and allow them to cool down completely
- If necessary, disconnect electrical connections from terminals.

The valve must be re-commissioned only with the correctly mounted actuator.

Disposal



Before disposal the valve must be dismantled and separated into its various constituent materials.

Legislation may demand special handling of certain components, or it may be sensible from an ecological point of view.

Current local legislation must be observed.

Warranty

The technical data given for these applications is valid only in conjunction with the Siemens actuators as detailed under "Equipment combinations", page 2.

All terms of the warranty will be invalidated by the use of actuators from other manufacturers.

Technical data

Operating data	PN class	PN 16 to EN1333
	Permissible operating pressure	1600 kPa (16 bar)
	Leakage rate	refer to "Type summary", page 2
	Permissible media	chilled water, low temperature hot water, high temperature hot water, brine, softened water, water with anti-freeze; recommendation: water treatment to VDI2035
	Medium temperature	-10...120 °C
	Flanged connection for pipes	PN 6, PN 10, PN 16 to ISO7005
	Angle of rotation	90° (to end stop)
	Standards	Pressure Equipment Directive
Pressure Accessories		as per article 1, section 2.1.4
Fluid group 2:		DN 40...50 without CE-marking as per article 3, section 3 (sound engineering practice) DN 65...200 category I, with CE-marking
Environmental compatibility		ISO 14001 (Environment) ISO 9001 (Quality) SN 36350 (Environmentally compatible products) RL 2002/95/EG (RoHS)
Materials	Housing	grey cast iron EN-GJL-250
	Shaft	stainless steel 1.4104
	Valve disc	stainless steel 1.4016
	Shaft seal	EPDM O-rings
Dimensions		refer to "Dimensions"
Weight		refer to "Dimensions"

Dimensions

VKF41.. with
SQK33.00, SQL33..
SQL83.00 and ASK33

Dimensions in mm

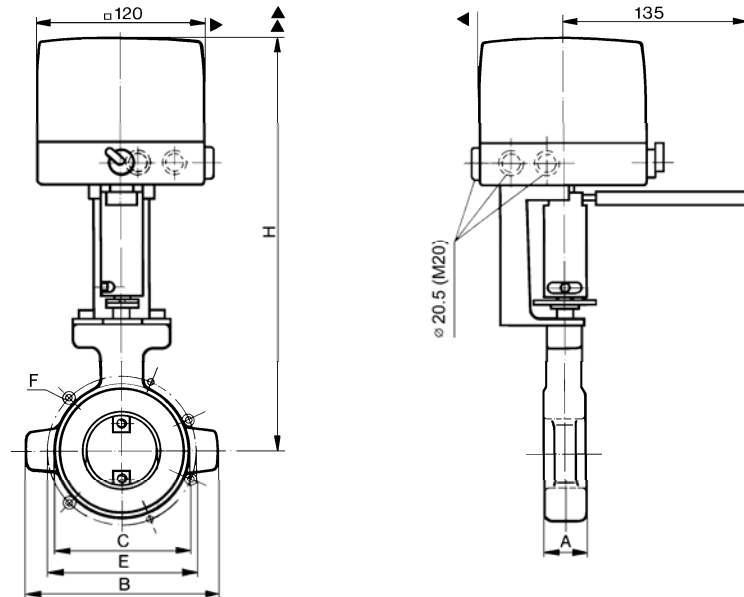

4131M01

VKF41.. with
SQL35.00, SQL85.00
and ASK35

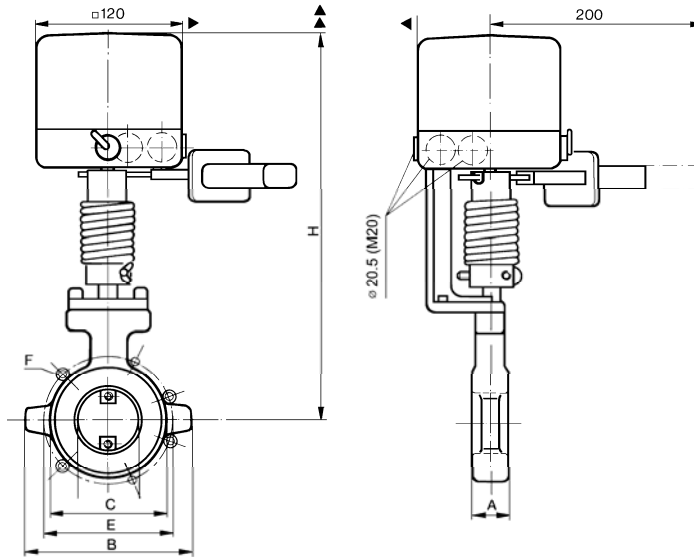

- ▶ > 100 mm: minimum clearance from the wall or ceiling
- ▶▶ > 200 mm: minimum clearance for mounting, connection, operation, maintenance etc

Type	DN	A	B ø	C ø	E		F		SQK33.00	H		kg [kg]
					PN 6		PN 10, PN 16			SQL33.. SQL83.00	SQL35.00 SQL85.00	
VKF41.40	40	30	130	87	100	M12 (4x)	110	M16 (4x)	249	275		1.72
VKF41.50	50	30	140	97	110	M12 (4x)	125	M16 (4x)		280		1.94
VKF41.65	65	30	160	117	130	M12 (4x)	145	M16 (4x)		287.5		2.37
VKF41.80	80	30	175	133	150	M16 (4x)	160	M16 (8x)		295		2.63
VKF41.100	100	30	195	153	170	M16 (4x)	180	M16 (8x)		305		2.92
VKF41.125	125	40	225	183	200	M16 (8x)	210	M16 (8x)		325.5		5.25
VKF41.150	150	40	255	208	225	M16 (8x)	240	M20 (8x)		338		6.29
VKF41.200	200	40	310	263	280	M16 (8x)	295	M20 (8x) for PN 10 M20 (12x) for PN 16	363	408	8.44	

DN = Nominal size
H = Total actuator height plus minimum distance to the wall or the ceiling for mounting, connection, operation, maintenance etc.

Spare parts

Order number for spare parts

	Centering sleeves	O-ring service kit
Product number		
VKF41.40	4 676 8877 0	4 679 8814 0
VKF41.50	4 676 8878 0	4 679 8814 0
VKF41.65	4 676 8878 0	4 679 8814 0
VKF41.80	4 676 8878 0	4 679 8814 0
VKF41.100	4 676 8878 0	4 679 8814 0
VKF41.125	4 676 8879 0	4 679 8815 0
VKF41.150	4 676 8880 0	4 679 8815 0
VKF41.200	4 676 8880 0	4 679 8815 0

Revision numbers

Type	Valid from rev. no.	Type	Valid from rev. no.	Type	Valid from rev. no.
VKF41.40	/01	VKF41.80	/01	VKF41.150	/01
VKF41.50	/01	VKF41.100	/01	VKF41.200	/01
VKF41.65	/01	VKF41.125	/01		